

PRICES EFFECTIVE
JANUARY 2011

SATI FLYE XX









s a v a

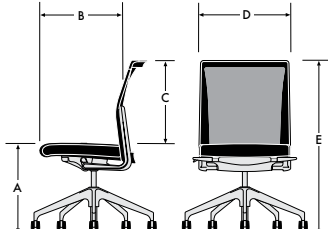
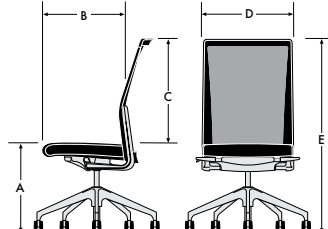
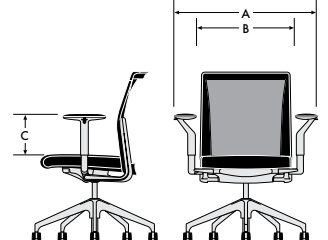
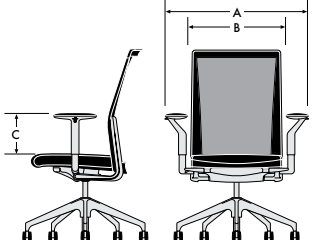
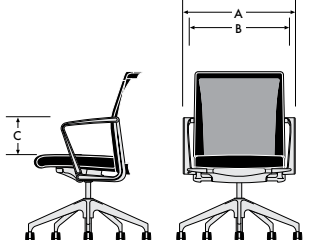
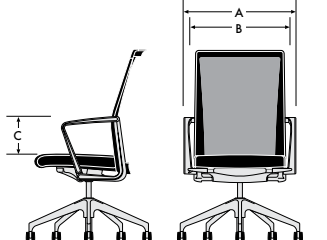

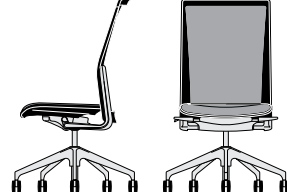
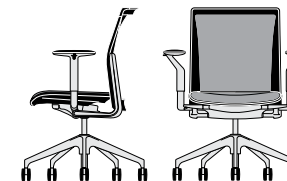
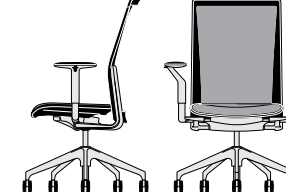
price list

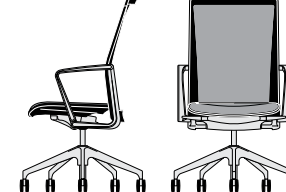

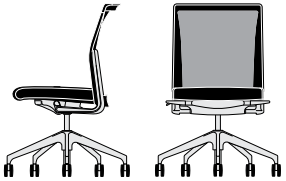
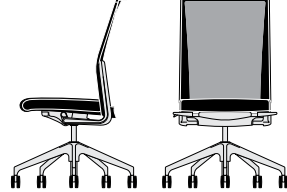
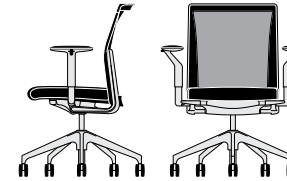
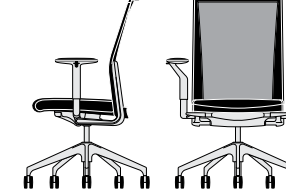
sava PRODUCT INFORMATION APPLICATIONS: CONFERENCE / MULTI-TASK	MEDIUM BACK	HIGH BACK	MEDIUM BACK	HIGH BACK	MEDIUM BACK	HIGH BACK	GENERAL INFORMATION
	DIMENSIONS / OVERVIEW						

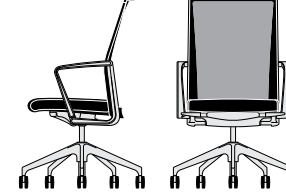

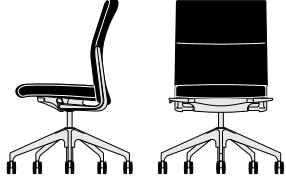
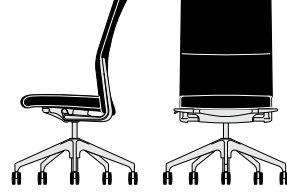
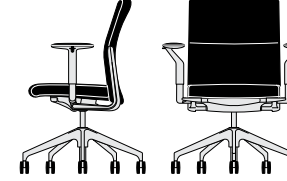
	SIZE 6 BACK	SIZE 8 BACK	ADJUSTABLE ARMS	FIXED ARMS		
--	--------------------	--------------------	------------------------	-------------------	--	--

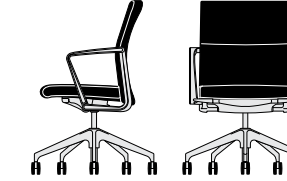
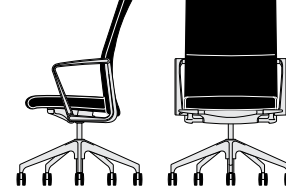
GENERAL DIMENSIONS A. SEAT HEIGHT* B. SEAT DEPTH C. BACK HEIGHT D. SEAT WIDTH & OVERALL WIDTH (ARMLESS) E. MAXIMUM OVERALL HEIGHT* <small>* MEASUREMENTS GIVEN ARE ACCURATE FOR 04 CONTROLS, UPHOLSTERED SEATS, AND MESH BACKS. SPECIFIC MODELS MAY VARY SLIGHTLY.</small>	A. 16"- 21" B. 16.5 - 18.5" C. 17.5" D. 22" E. 33"- 38" 	A. 16"- 21" B. 16.5 - 18.5" C. 22.5" D. 20.5" E. 37.5"- 42.5" 	A. OVERALL WIDTH B. DISTANCE BETWEEN ARMS* C. ARM HEIGHT * ARMS ROTATE INWARD 45° 	A. 27.5" B. 20.5" C. 6"- 10" 	A. OVERALL WIDTH B. DISTANCE BETWEEN ARMS C. ARM HEIGHT 	A. 23.5" B. 21" C. 7.75" 	DESIGN SAVA CVECK SUSTAINABILITY SAVA WAS DESIGNED TO MEET THE REQUIREMENTS OF CONTEMPORARY STANDARDS OF SUSTAINABILITY, INCLUDING A HIGH LEVEL OF RECYCLABILITY. FURTHERMORE, ITS EASILY FIELD-REPLACEABLE COMPONENTS AND SOLID CONSTRUCTION WILL ENSURE A LONG PRODUCT LIFE WITH A HIGH DEGREE OF USER SATISFACTION. GREENGUARD CERTIFICATION SAVA IS GREENGUARD CERTIFIED. BACK CONSTRUCTION UPHOLSTERED BACKS UPHOLSTERED BACKS ARE BUILT AROUND AN INTERNAL FRAME OF WELDED STEEL ROD INTEGRATED WITH A FLEXIBLE B-SURFACE MATERIAL AND COVERED WITH MOLDED CFC-FREE POLYURETHANE FOAM. MESH BACKS MESH BACKS UTILIZE INJECTION-MOLDED, GLASS-FILLED FRAMES TO WHICH THE MESH IS APPLIED. APPLICATION OF THE MESH TO THE FRAMES IS ACHIEVED THROUGH A PATENTED PROCESS TO ENHANCE BOTH COMFORT AND PERFORMANCE.
	UPHOLSTERY OPTIONS MESH 						

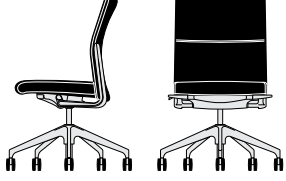
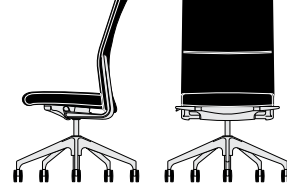
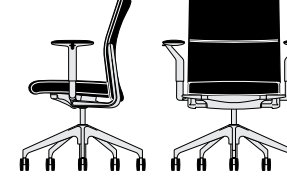
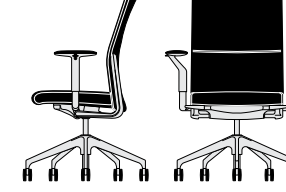
MESH BACK UPHOLSTERED SEAT 					
--	--	---	---	---	---

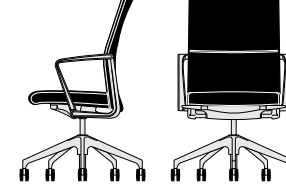
STANDARD UPHOLSTERY 						
--	---	--	---	---	---	---

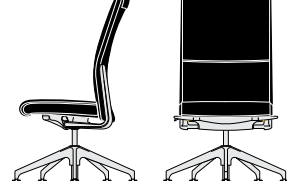
EURO UPHOLSTERY 						
--	---	--	---	---	---	---

THIN PAD UPHOLSTERY 			
--	--	---	---

MECHANISM AND BACK SUPPORTS THE MECHANISM IS LARGELY COMPOSED OF ALUMINUM AND STEEL COMPONENTS. IT FUNCTIONS THROUGH A SYSTEM OF TWO MAIN SPRINGS AND CAMS WHICH WORK INTERACTIVELY TO CONTROL TENSION. MULTI-TASK MODELS ON UPHOLSTERED SEATS OFFER FOUR ADJUSTMENTS; ON MESH SEATS, THE MULTI-TASK CONTROL HAS THREE ADJUSTMENTS. CONFERENCE MODELS HAVE TWO ADJUSTMENTS. THE CONTROL PADDLES ARE PLASTIC WITH INSET ICONS TO PROVIDE USER GUIDANCE. BACK SUPPORTS, ATTACHED TO THE CONTROL BY METAL FASTENERS, ARE ALUMINUM.

ARMS ADJUSTABLE ARMS ADJUSTABLE ARMS ARE PRIMARILY CAST ALUMINUM FOR GREATER DURABILITY. CAPS ARE FLEXIBLE POLYURETHANE FOAM THAT MAY BE UPHOLSTERED BASED ON THE USER'S PREFERENCE. FIXED ARMS FIXED ARMS ARE CAST ALUMINUM AND MAY BE SPECIFIED WITH PLASTIC CAPS.

BASE BASES ARE CAST ALUMINUM.

sava

**CONFERENCE - MULTI-TASK
MESH SEAT AND BACK**

DESCRIPTION

MESH

		SERIES	STYLE	SIZE	CONTROL	ARMS	DESCRIPTION	MESH
	MEDIUM BACK	SV	1	6	2	00	ARMLESS, CONFERENCE	1,240
		SV	1	6	3	00	ARMLESS, MULTI-TASK	1,320
		SV	1	6	2	01	ADJUSTABLE T ARMS, CONFERENCE	1,540
		SV	1	6	3	01	ADJUSTABLE T ARMS, MULTI-TASK	1,620
		SV	1	6	2	07	FIXED D ARMS, CONFERENCE	1,350
		SV	1	6	3	07	FIXED D ARMS, MULTI-TASK	1,430
	HIGH BACK	SV	1	8	2	00	ARMLESS, CONFERENCE	1,265
		SV	1	8	3	00	ARMLESS, MULTI-TASK	1,345
		SV	1	8	2	01	ADJUSTABLE T ARMS, CONFERENCE	1,565
		SV	1	8	3	01	ADJUSTABLE T ARMS, MULTI-TASK	1,645
		SV	1	8	2	07	FIXED D ARMS, CONFERENCE	1,375
		SV	1	8	3	07	FIXED D ARMS, MULTI-TASK	1,455

1 SERIES/STYLE/SIZE 2 CONTROLS/FUNCTION 3 ARM CHOICES 4 MESH CHOICES 5 GENERAL OPTIONS 6 CASTER OPTIONS 7 FINISH CHOICES 8 COVER

TO ORDER FOLLOW STEPS 1-8

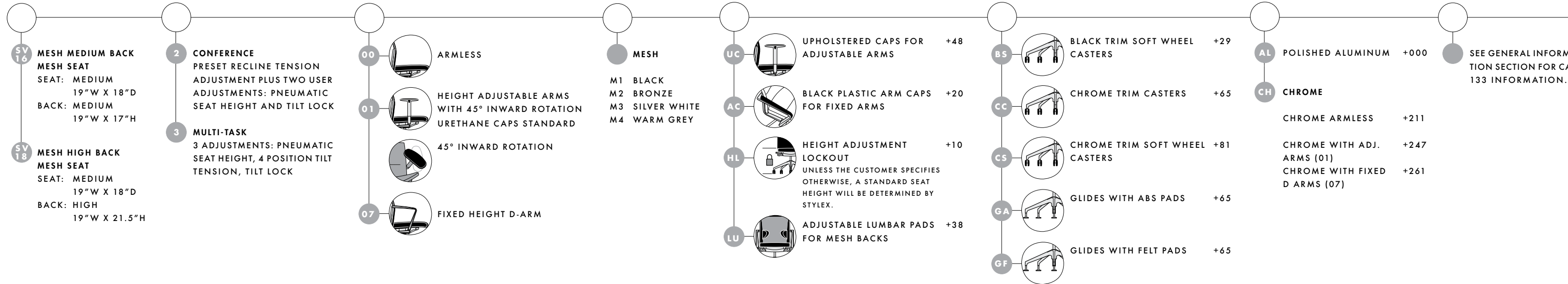

sava
CONFERENCE - MULTI-TASK
UPHOLSTERED SEAT - MESH BACK

DESCRIPTION

C.O.M.

C.O.L.

FABRIC
 UPHOLSTERY
 GRADES

C.O.M.

C.O.L.

LEATHER UPHOLSTERY
 GRADES

EDELMAN LEATHER
 UPHOLSTERY
 GRADES

SERIES	STYLE	SIZE	CONTROL	ARMS	DESCRIPTION	YDG.	SQ.FT.	A	B	C	D	E	F	G	H	I	J	W	X	Y	E1	E2
SV	2	6	2	00	ARMLESS, CONFERENCE	0.8	10	1,117	1,142	1,167	1,192	1,217	1,244	1,270	1,302	1,333	1,369	1,296	1,321	1,387	1,442	1,534
				00	ARMLESS, MULTI-TASK	0.8	10	1,197	1,222	1,247	1,272	1,297	1,324	1,350	1,382	1,413	1,449	1,376	1,401	1,467	1,522	1,614
SV	2	6	2	01	ADJUSTABLE T ARMS, CONFERENCE	0.8	10	1,417	1,442	1,467	1,492	1,517	1,544	1,570	1,602	1,633	1,669	1,596	1,621	1,687	1,742	1,834
				01	ADJUSTABLE T ARMS, MULTI-TASK	0.8	10	1,497	1,522	1,547	1,572	1,597	1,624	1,650	1,682	1,713	1,749	1,676	1,701	1,767	1,822	1,914
SV	2	6	2	07	FIXED D ARMS, CONFERENCE	0.8	10	1,227	1,252	1,277	1,302	1,327	1,354	1,380	1,412	1,443	1,479	1,406	1,431	1,497	1,552	1,644
				07	FIXED D ARMS, MULTI-TASK	0.8	10	1,307	1,332	1,357	1,382	1,407	1,434	1,460	1,492	1,523	1,559	1,486	1,511	1,577	1,632	1,724
SV	2	8	2	00	ARMLESS, CONFERENCE	0.8	10	1,138	1,163	1,188	1,213	1,238	1,265	1,291	1,323	1,354	1,390	1,317	1,342	1,408	1,463	1,555
				00	ARMLESS, MULTI-TASK	0.8	10	1,218	1,243	1,268	1,293	1,318	1,345	1,371	1,403	1,434	1,470	1,397	1,422	1,488	1,543	1,635
SV	2	8	2	01	ADJUSTABLE T ARMS, CONFERENCE	0.8	10	1,438	1,463	1,488	1,513	1,538	1,565	1,591	1,623	1,654	1,690	1,617	1,642	1,708	1,763	1,855
				01	ADJUSTABLE T ARMS, MULTI-TASK	0.8	10	1,518	1,543	1,568	1,593	1,618	1,645	1,671	1,703	1,734	1,770	1,697	1,722	1,788	1,843	1,935
SV	2	8	2	07	FIXED D ARMS, CONFERENCE	0.8	10	1,248	1,273	1,298	1,323	1,348	1,375	1,401	1,433	1,464	1,500	1,427	1,452	1,518	1,573	1,665
				07	FIXED D ARMS, MULTI-TASK	0.8	10	1,328	1,353	1,378	1,403	1,428	1,455	1,481	1,513	1,544	1,580	1,507	1,532	1,598	1,653	1,745

1 SERIES/STYLE/SIZE 2 CONTROLS/FUNCTION 3 ARM CHOICES 4 MESH CHOICES 5 GENERAL OPTIONS 6 CASTER OPTIONS 7 FINISH CHOICES 8 COVER

TO ORDER FOLLOW STEPS 1-8

SV 26 MESH MEDIUM BACK UPHOLSTERED SEAT
 SEAT: MEDIUM 19"W X 18"D
 BACK: MEDIUM 19"W X 17"H

SV 28 MESH HIGH BACK UPHOLSTERED SEAT
 SEAT: MEDIUM 19"W X 18"D
 BACK: HIGH 19"W X 21.5"H

2 CONFERENCE
 PRESET RECLINE TENSION ADJUSTMENT PLUS TWO USER ADJUSTMENTS: PNEUMATIC SEAT HEIGHT AND TILT LOCK

4 MULTI-TASK
 4 ADJUSTMENTS: PNEUMATIC SEAT HEIGHT, 4 POSITION TILT TENSION, TILT LOCK, SEAT DEPTH

00 ARMLESS

01 HEIGHT ADJUSTABLE ARMS WITH 45° INWARD ROTATION URETHANE CAPS STANDARD

01 45° INWARD ROTATION

07 FIXED HEIGHT D-ARM

MESH

M1 BLACK
 M2 BRONZE
 M3 SILVER WHITE
 M4 WARM GREY

UC UPHOLSTERED CAPS FOR ADJUSTABLE ARMS +48

AC BLACK PLASTIC ARM CAPS FOR FIXED ARMS +20

HL HEIGHT ADJUSTMENT LOCKOUT UNLESS THE CUSTOMER SPECIFIES OTHERWISE, A STANDARD SEAT HEIGHT WILL BE DETERMINED BY STYLEX. +10

LU ADJUSTABLE LUMBAR PADS FOR MESH BACKS +38

CT CONTRASTING THREAD +00

BS BLACK TRIM SOFT WHEEL CASTERS +29

CC CHROME TRIM CASTERS +65

CS CHROME TRIM SOFT WHEEL CASTERS +81

GA GLIDES WITH ABS PADS +65

GF GLIDES WITH FELT PADS +65

AL POLISHED ALUMINUM +000

CH CHROME

CHROME ARMLESS +180

CHROME WITH ADJ. ARMS (01) +216

CHROME WITH FIXED D ARMS (07) +230

SEE SWATCH CARDS FOR STANDARD UPHOLSTERY OPTIONS.

SEE GENERAL INFORMATION SECTION FOR DETAILS ON COM AND IN-GRADED FABRIC PROGRAM.

SEE GENERAL INFORMATION SECTION FOR CAL 133 INFORMATION.

DESCRIPTION

C.O.M.

C.O.L.

FABRIC
UPHOLSTERY
GRADES

C.O.M.

C.O.L.

LEATHER UPHOLSTERY
GRADES

EDELMAN LEATHER
UPHOLSTERY
GRADES

SERIES	STYLE	SIZE	CONTROL	ARMS	DESCRIPTION	YDG.	SQ.FT.	A	B	C	D	E	F	G	H	I	J	W	X	Y	E1	E2
SV	4	6	2	00	ARMLESS, CONFERENCE	1.5	24	1,232	1,280	1,327	1,373	1,421	1,471	1,520	1,580	1,639	1,705	1,692	1,751	1,911	2,092	2,262
				00	ARMLESS, MULTI-TASK	1.5	24	1,312	1,360	1,407	1,453	1,501	1,551	1,600	1,660	1,719	1,785	1,772	1,831	1,991	2,172	2,342
SV	4	6	2	01	ADJUSTABLE T ARMS, CONFERENCE	1.5	24	1,532	1,580	1,627	1,673	1,721	1,771	1,820	1,880	1,939	2,005	1,992	2,051	2,211	2,392	2,562
				01	ADJUSTABLE T ARMS, MULTI-TASK	1.5	24	1,612	1,660	1,707	1,753	1,801	1,851	1,900	1,960	2,019	2,085	2,072	2,131	2,291	2,472	2,642
SV	4	6	2	07	FIXED D ARMS, CONFERENCE	1.5	24	1,342	1,390	1,437	1,483	1,531	1,581	1,630	1,690	1,749	1,815	1,802	1,861	2,021	2,202	2,372
				07	FIXED D ARMS, MULTI-TASK	1.5	24	1,422	1,470	1,517	1,563	1,611	1,661	1,710	1,770	1,829	1,895	1,882	1,941	2,101	2,282	2,452
SV	4	8	2	00	ARMLESS, CONFERENCE	1.7	25	1,267	1,321	1,374	1,426	1,481	1,537	1,593	1,661	1,727	1,802	1,779	1,848	2,034	2,187	2,444
				00	ARMLESS, MULTI-TASK	1.7	25	1,347	1,401	1,454	1,506	1,561	1,617	1,673	1,741	1,807	1,882	1,859	1,928	2,114	2,267	2,524
SV	4	8	2	01	ADJUSTABLE T ARMS, CONFERENCE	1.7	25	1,567	1,621	1,674	1,726	1,781	1,837	1,893	1,961	2,027	2,102	2,079	2,148	2,334	2,487	2,744
				01	ADJUSTABLE T ARMS, MULTI-TASK	1.7	25	1,647	1,701	1,754	1,806	1,861	1,917	1,973	2,041	2,107	2,182	2,159	2,228	2,414	2,567	2,824
SV	4	8	2	07	FIXED D ARMS, CONFERENCE	1.7	25	1,377	1,431	1,484	1,536	1,591	1,647	1,703	1,771	1,837	1,912	1,889	1,958	2,144	2,297	2,554
				07	FIXED D ARMS, MULTI-TASK	1.7	25	1,457	1,511	1,564	1,616	1,671	1,727	1,783	1,851	1,917	1,992	1,969	2,038	2,224	2,377	2,634

1 SERIES/STYLE/SIZE 2 CONTROLS/FUNCTION 3 ARM CHOICES 4 GENERAL OPTIONS 5 CASTER OPTIONS 6 FINISH CHOICES 7 COVER

TO ORDER FOLLOW STEPS 1-7

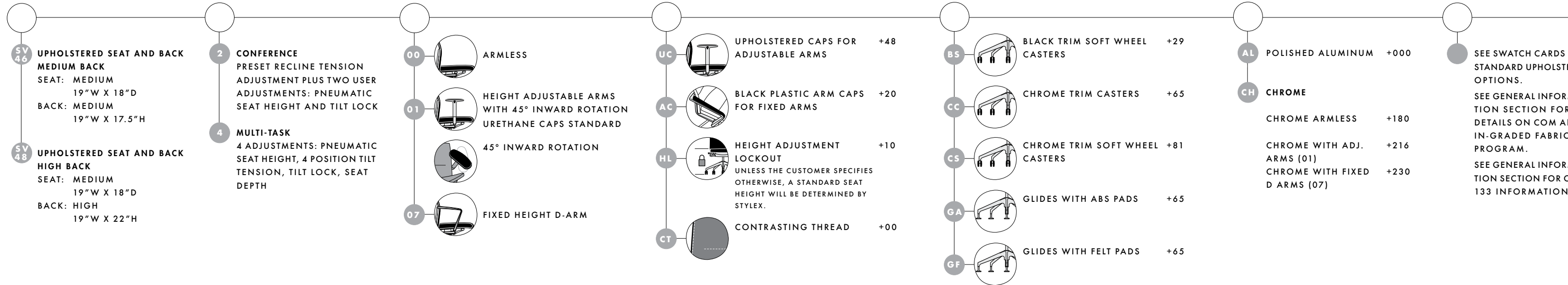

sava
CONFERENCE - MULTI-TASK
EURO UPHOLSTERY

DESCRIPTION

C.O.M.

C.O.L.







FABRIC UPHOLSTERY GRADES

C.O.M.

C.O.L.

LEATHER UPHOLSTERY GRADES

EDELMAN LEATHER UPHOLSTERY GRADES

SERIES	STYLE	SIZE	CONTROL	ARMS	DESCRIPTION	YDG.	SQ.FT.	A	B	C	D	E	F	G	H	I	J	W	X	Y	E1	E2		
	SV	MEDIUM BACK	5	6	2	00	ARMLESS, CONFERENCE	1.5	24	1,232	1,280	1,327	1,373	1,421	1,471	1,520	1,580	1,639	1,705	1,692	1,751	1,911	2,092	2,262
		SV	5	6	4	00	ARMLESS, MULTI-TASK	1.5	24	1,312	1,360	1,407	1,453	1,501	1,551	1,600	1,660	1,719	1,785	1,772	1,831	1,991	2,172	2,342
	SV	5	6	2	01	ADJUSTABLE T ARMS, CONFERENCE	1.5	24	1,532	1,580	1,627	1,673	1,721	1,771	1,820	1,880	1,939	2,005	1,992	2,051	2,211	2,392	2,562	
		SV	5	6	4	01	ADJUSTABLE T ARMS, MULTI-TASK	1.5	24	1,612	1,660	1,707	1,753	1,801	1,851	1,900	1,960	2,019	2,085	2,072	2,131	2,291	2,472	2,642
	SV	5	6	2	07	FIXED D ARMS, CONFERENCE	1.5	24	1,342	1,390	1,437	1,483	1,531	1,581	1,630	1,690	1,749	1,815	1,802	1,861	2,021	2,202	2,372	
		SV	5	6	4	07	FIXED D ARMS, MULTI-TASK	1.5	24	1,422	1,470	1,517	1,563	1,611	1,661	1,710	1,770	1,829	1,895	1,882	1,941	2,101	2,282	2,452
	SV	HIGH BACK	5	8	2	00	ARMLESS, CONFERENCE	1.7	25	1,267	1,321	1,374	1,426	1,481	1,537	1,593	1,661	1,727	1,802	1,779	1,848	2,034	2,187	2,444
		SV	5	8	4	00	ARMLESS, MULTI-TASK	1.7	25	1,347	1,401	1,454	1,506	1,561	1,617	1,673	1,741	1,807	1,882	1,859	1,928	2,114	2,267	2,524
	SV	5	8	2	01	ADJUSTABLE T ARMS, CONFERENCE	1.7	25	1,567	1,621	1,674	1,726	1,781	1,837	1,893	1,961	2,027	2,102	2,079	2,148	2,334	2,487	2,744	
		SV	5	8	4	01	ADJUSTABLE T ARMS, MULTI-TASK	1.7	25	1,647	1,701	1,754	1,806	1,861	1,917	1,973	2,041	2,107	2,182	2,159	2,228	2,414	2,567	2,824
	SV	5	8	2	07	FIXED D ARMS, CONFERENCE	1.7	25	1,377	1,431	1,484	1,536	1,591	1,647	1,703	1,771	1,837	1,912	1,889	1,958	2,144	2,297	2,554	
		SV	5	8	4	07	FIXED D ARMS, MULTI-TASK	1.7	25	1,457	1,511	1,564	1,616	1,671	1,727	1,783	1,851	1,917	1,992	1,969	2,038	2,224	2,377	2,634

1 SERIES/STYLE/SIZE 2 CONTROLS/FUNCTION 3 ARM CHOICES 4 GENERAL OPTIONS 5 CASTER OPTIONS 6 FINISH CHOICES 7 COVER

TO ORDER FOLLOW STEPS 1-7

SV 56 UPHOLSTERED SEAT AND BACK MEDIUM BACK
 SEAT: MEDIUM 19"W X 18"D
 BACK: MEDIUM 19"W X 17.5"H

SV 58 UPHOLSTERED SEAT AND BACK HIGH BACK
 SEAT: MEDIUM 19"W X 18"D
 BACK: HIGH 19"W X 22"H

2 CONFERENCE PRESET RECLINE TENSION ADJUSTMENT PLUS TWO USER ADJUSTMENTS: PNEUMATIC SEAT HEIGHT AND TILT LOCK

4 MULTI-TASK 4 ADJUSTMENTS: PNEUMATIC SEAT HEIGHT, 4 POSITION TILT TENSION, TILT LOCK, SEAT DEPTH

00 ARMLESS

01 HEIGHT ADJUSTABLE ARMS WITH 45° INWARD ROTATION URETHANE CAPS STANDARD

45° INWARD ROTATION

07 FIXED HEIGHT D-ARM

UC UPHOLSTERED CAPS FOR ADJUSTABLE ARMS +48

AC BLACK PLASTIC ARM CAPS FOR FIXED ARMS +20

HL HEIGHT ADJUSTMENT LOCKOUT UNLESS THE CUSTOMER SPECIFIES OTHERWISE, A STANDARD SEAT HEIGHT WILL BE DETERMINED BY STYLEX. +10

CT CONTRASTING THREAD +00

BS BLACK TRIM SOFT WHEEL CASTERS +29

CC CHROME TRIM CASTERS +65

CS CHROME TRIM SOFT WHEEL CASTERS +81

GA GLIDES WITH ABS PADS +65

GF GLIDES WITH FELT PADS +65

AL POLISHED ALUMINUM +000

CH CHROME

CHROME ARMLESS +180

CHROME WITH ADJ. ARMS (01) +216

CHROME WITH FIXED D ARMS (07) +230

SEE SWATCH CARDS FOR STANDARD UPHOLSTERY OPTIONS.

SEE GENERAL INFORMATION SECTION FOR DETAILS ON COM AND IN-GRADED FABRIC PROGRAM.

SEE GENERAL INFORMATION SECTION FOR CAL 133 INFORMATION.

sava
CONFERENCE - MULTI-TASK
THIN PAD UPHOLSTERY

		C.O.M.		C.O.L.		C.O.M.		C.O.L.		LEATHER UPHOLSTERY GRADES		EDELMAN LEATHER UPHOLSTERY GRADES											
SERIES	STYLE	SIZE	CONTROL	ARMS	YDG.	SQ.FT.	A	B	C	D	E	F	G	H	I	J	W	X	Y	E1	E2		
	HIGH BACK																						
	SV	7	8	2	00	ARMLESS, CONFERENCE	2.2	34	1,352	1,423	1,491	1,559	1,630	1,702	1,775	1,863	1,949	2,045	2,115	2,222	2,510	2,790	3,202
	SV	7	8	4	00	ARMLESS, MULTI-TASK	2.2	34	1,432	1,503	1,571	1,639	1,710	1,782	1,855	1,943	2,029	2,125	2,195	2,302	2,590	2,870	3,282
	SV	7	8	2	01	ADJUSTABLE T ARMS, CONFERENCE	2.2	34	1,652	1,723	1,791	1,859	1,930	2,002	2,075	2,163	2,249	2,345	2,415	2,522	2,810	3,090	3,502
	SV	7	8	4	01	ADJUSTABLE T ARMS, MULTI-TASK	2.2	34	1,732	1,803	1,871	1,939	2,010	2,082	2,155	2,243	2,329	2,425	2,495	2,602	2,890	3,170	3,582
	SV	7	8	2	07	FIXED D ARMS, CONFERENCE	2.2	34	1,462	1,533	1,601	1,669	1,740	1,812	1,885	1,973	2,059	2,155	2,225	2,332	2,620	2,900	3,312
	SV	7	8	4	07	FIXED D ARMS, MULTI-TASK	2.2	34	1,542	1,613	1,681	1,749	1,820	1,892	1,965	2,053	2,139	2,235	2,305	2,412	2,700	2,980	3,392

