

PRICES EFFECTIVE
JANUARY 2011

STREETX

mg lounge



price list

DIMENSIONS / OVERVIEW

FOUR LEG

FOUR LEG ARM

GENERAL DIMENSIONS

- A. AVERAGE SEAT HEIGHT
- B. SEAT DEPTH
- C. OVERALL HEIGHT
- D. OVERALL DEPTH

24" WIDE ARMLESS CHAIR

- E. OVERALL WIDTH
- F. SEAT & BACK WIDTH

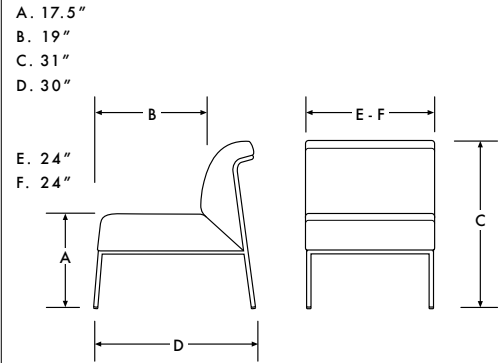

GENERAL DIMENSIONS

- A. AVERAGE SEAT HEIGHT
- B. SEAT DEPTH
- C. OVERALL HEIGHT
- D. OVERALL DEPTH

ARM CHAIR

- E. OVERALL WIDTH
- F. SEAT & BACK WIDTH

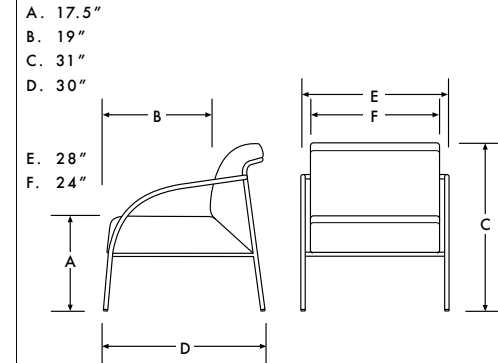

DESIGN
MARK GOETZ

CONSTRUCTION

SEATS AND BACKS INCORPORATE COMPOUND CURVED PLYWOOD UNDER HIGH-DENSITY, CFC-FREE POLYURETHANE FOAM. FRAMES ARE 13-GAUGE, HIGH-STRENGTH STEEL TUBE. EXPOSED JOINTS ARE TIG WELDED.

GLIDES

GLIDES ARE PLASTIC.

GANGING

CHAIRS CAN BE GANGED WITH FIELD-INSTALLED BRACKETS. IF DESIRED, BRACKETS CAN LATER BE REMOVED.

FINISHES

THREE STYLEX PAINT FINISHES (TEXTURED BLACK, GLOSSY BLACK, AND METALLIC SILVER) ARE AVAILABLE ALONG WITH CHROME.

USE

DESIGNED FOR INDOOR USE ONLY.

TESTING

MANUFACTURED TO COMPLY WITH THE ANSI/BIFMA X5.4 LOUNGE SEATING STANDARD.

ENVIRONMENT

GREENGUARD CERTIFIED.

28" WIDE ARMLESS CHAIR

- E. OVERALL WIDTH
- F. SEAT & BACK WIDTH

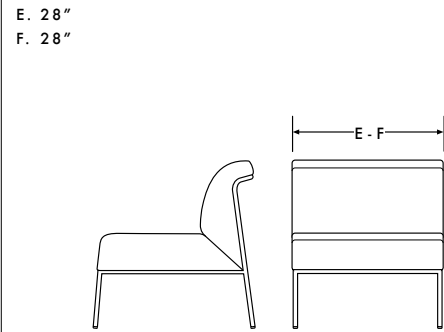

SINGLE ARM CHAIR RIGHT HAND

- E. OVERALL WIDTH
- F. SEAT & BACK WIDTH

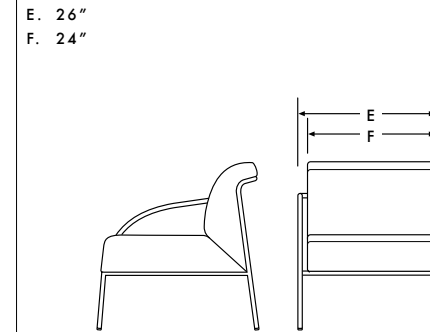

SINGLE ARM CHAIR LEFT HAND

- E. OVERALL WIDTH
- F. SEAT & BACK WIDTH

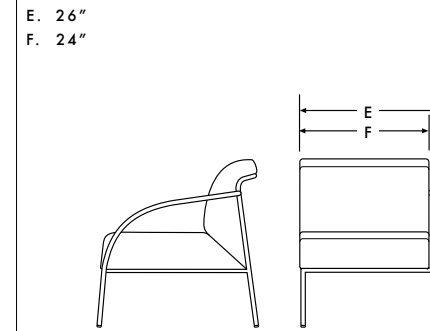

DIMENSIONS / OVERVIEW

FOUR LEG BENCH 30" DEEP

FOUR LEG BENCH 24" DEEP

GENERAL DIMENSIONS

A. OVERALL HEIGHT

24" WIDTH

B. OVERALL DEPTH

C. OVERALL WIDTH

A. 17.5"

B. 30"

C. 24"

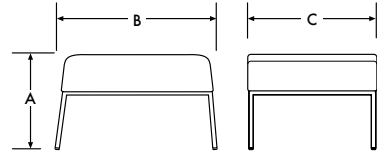

28" WIDTH

B. OVERALL DEPTH

C. OVERALL WIDTH

B. 30"

C. 28"

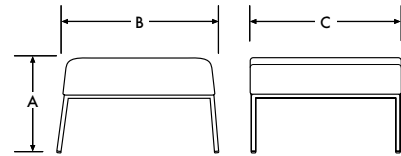

48" WIDTH

B. OVERALL DEPTH

C. OVERALL WIDTH

B. 30"

C. 48"

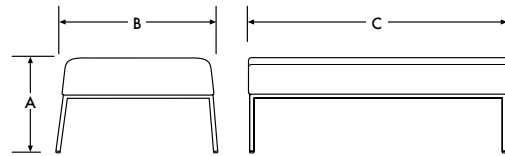

B. 24"

C. 48"

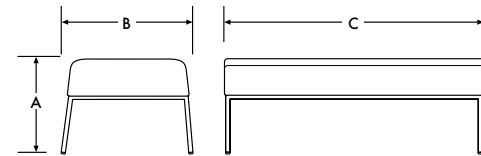

DESIGN
MARK GOETZ

CONSTRUCTION
SEATS AND BACKS INCORPORATE COMPOUND CURVED PLYWOOD UNDER HIGH-DENSITY, CFC-FREE POLYURETHANE FOAM. FRAMES ARE 13-GAUGE, HIGH-STRENGTH STEEL TUBE. EXPOSED JOINTS ARE TIG WELDED.

GLIDES
GLIDES ARE PLASTIC.

GANGING
CHAIRS CAN BE GANGED WITH FIELD-INSTALLED BRACKETS. IF DESIRED, BRACKETS CAN LATER BE REMOVED.

FINISHES
THREE STYLEX PAINT FINISHES (TEXTURED BLACK, GLOSSY BLACK, AND METALLIC SILVER) ARE AVAILABLE ALONG WITH CHROME.

USE
DESIGNED FOR INDOOR USE ONLY.

TESTING
MANUFACTURED TO COMPLY WITH ANSI/BIFMA X5.1 GENERAL OFFICE CHAIR TESTS.

ENVIRONMENT
GREENGUARD CERTIFIED.

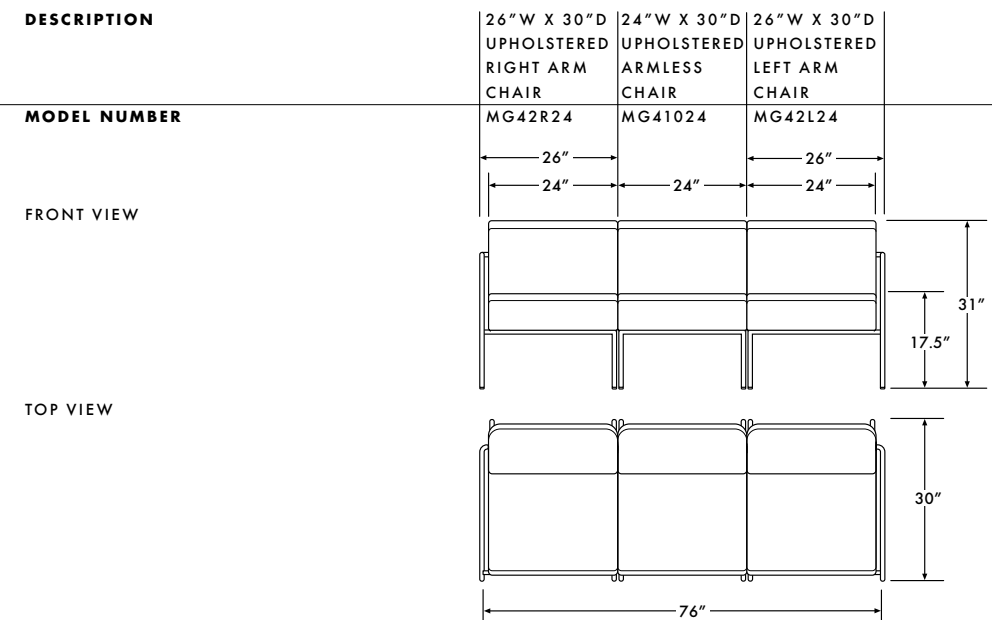
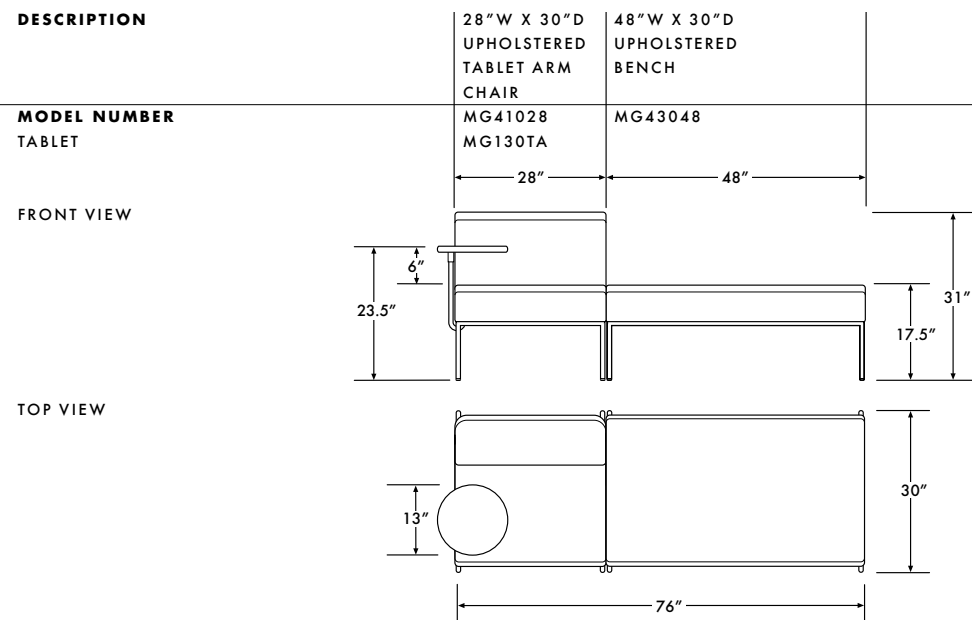
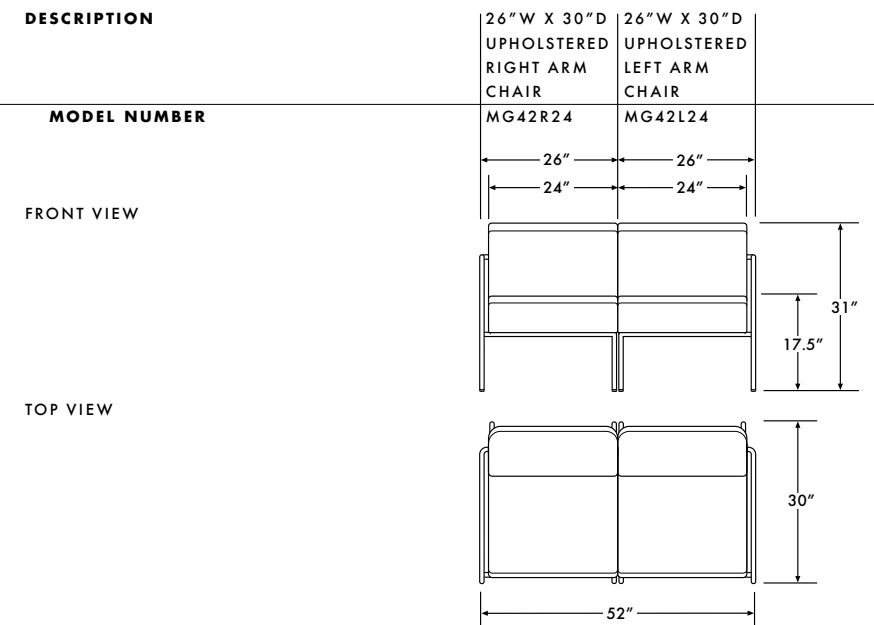
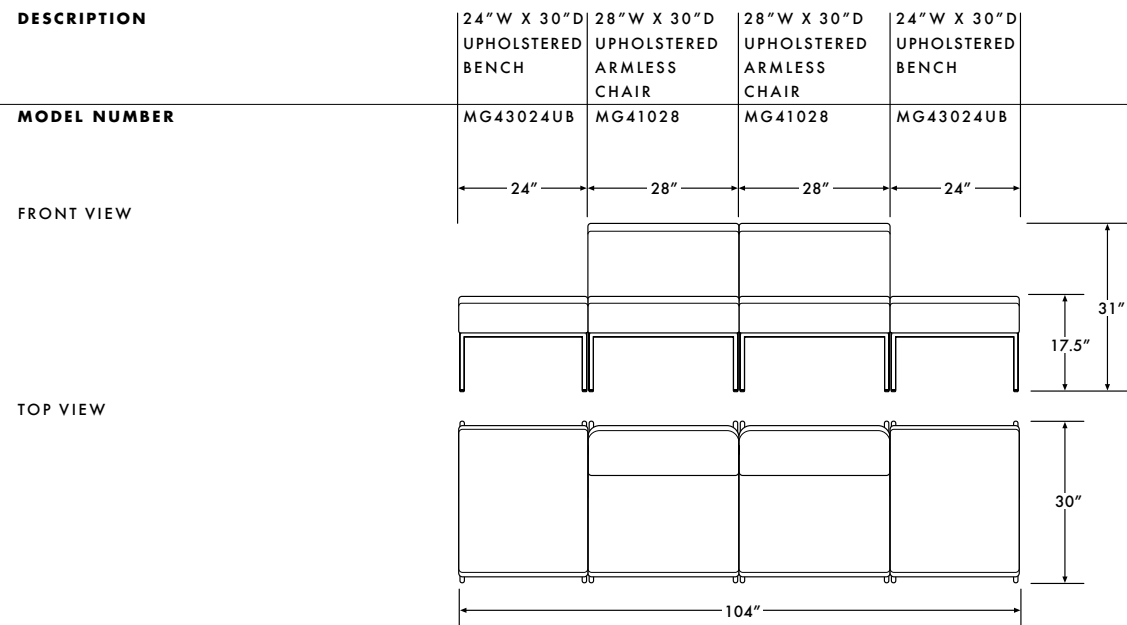

mg lounge

FOUR LEG
UPHOLSTERED BENCHES

DESCRIPTION

FABRIC
UPHOLSTERY
GRADES

LEATHER
UPHOLSTERY
GRADES

C.O.M.

C.O.L.

C.O.M.

C.O.L.

SERIES	FRAME	DEPTH	WIDTH	STYLE	FRAME FINISH CHOICES	YDG.	SQ.FT.	A	B	C	D	E	F	G	H	I	J	W	X	Y
MG	4	30	24	UB	CHROME OR POWDER COAT	2.0	14	866	913	957	1,003	1,048	1,097	1,145	1,203	1,259	1,323	1,142	1,149	1,265
MG	4	30	28	UB	CHROME OR POWDER COAT	2.0	16	894	944	993	1,040	1,090	1,142	1,192	1,254	1,315	1,384	1,165	1,221	1,293
MG	4	30	48	UB	CHROME OR POWDER COAT	2.0	24	1,146	1,212	1,276	1,340	1,407	1,475	1,543	1,626	1,707	1,798	1,565	1,652	1,858
MG	4	24	48	UB	CHROME OR POWDER COAT	2.0	20	950	997	1,041	1,087	1,132	1,181	1,229	1,287	1,342	1,407	1,295	1,366	1,537

TO ORDER **1 SERIES/FRAME/STYLE** **2 OPTIONS** **3 FRAME FINISH CHOICES** **4 COVER**

FOLLOW STEPS 1 - 4 TO
CONSTRUCT A MODEL NUMBER.

SEE INTRODUCTORY PRODUCT
SPECIFICATION PAGES FOR
ADDITIONAL INFORMATION.



- MG 43024UB**
30" X 24" FOUR LEG UPHOLSTERED BENCH
- MG 43028UB**
30" X 28" FOUR LEG UPHOLSTERED BENCH
- MG 43048UB**
30" X 48" FOUR LEG UPHOLSTERED BENCH
- MG 42448UB**
24" X 48" FOUR LEG UPHOLSTERED BENCH

SEE TABLET ARM PAGES FOR DETAILS.



- GA** GANGING BRACKET +31
ONE GANGING BRACKET
SECURES TWO UNITS. FIELD-IN-
STALLABLE. UNITS WITH ARMS
ON BOTH SIDES MAY NOT BE
GANGED. UNITS WITH AN ARM
ON ONE SIDE MAY BE GANGED
ON THE SIDE WITHOUT AN ARM.

WHEN GANGING A GROUP OF
CHAIRS, CALCULATE THE NUM-
BER OF CHAIRS TO ORDER WITH
BRACKETS BY TOTALING THE
NUMBER OF CHAIRS GANGED
TOGETHER AND SUBTRACTING
ONE.



- CF** CONTRASTING FABRIC +104
CHARGED FOR EACH CONTRASTING
FABRIC COMBINATION SPECIFIED.
LIST PRICE IS BASED ON THE HIGHER
GRADE SPECIFIED. C.O.M. REQUIRE-
MENTS SHOWN BELOW.

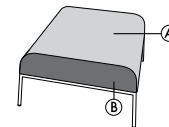

CONTRASTING FABRIC C.O.M
REQUIREMENTS PER CHAIR

MODEL	"A" SURFACE	"B" SURFACE
MG43024UB	0.8	0.6
MG43028UB	1.0	0.6
MG43048UB	1.5	0.6
MG42424UB	0.8	0.6
MG42448UB	0.8	0.6



- STANDARD POWDER PAINT**
TB TEXTURED BLACK
GB GLOSSY BLACK
- DOUBLE COAT POWDER PAINT***
MS METALLIC SILVER
* INCLUDES A PROTECTIVE
CLEAR COAT
- CH BRIGHT CHROME**



REFER TO STYLEX SWATCH
CARDS AND SEPARATELY
PUBLISHED IN-GRADED
FABRIC PROGRAM TO
DETERMINE GRADES.
SEE GENERAL INFORMA-
TION SECTION FOR CAL
133 INFORMATION.

mg lounge

FOUR LEG WOOD TABLE BENCHES
IN-LINE WOOD CONNECTING TABLE

DESCRIPTION

VENEERS

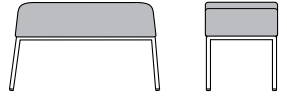
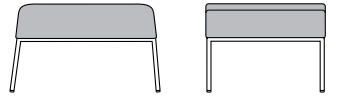
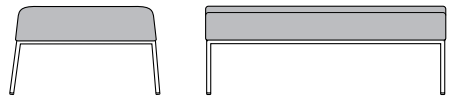
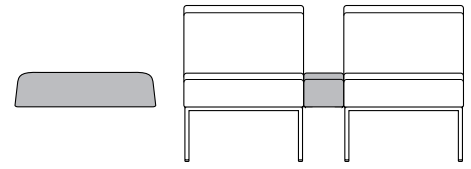
SERIES	FRAME	DEPTH	WIDTH	STYLE	FRAME FINISH CHOICES	STANDARD VENEERS
						
MG	4	30	14	TB	CHROME OR POWDER COAT	1,087
						
MG	4	30	24	TB	CHROME OR POWDER COAT	1,449
						
MG	4	30	48	TB	CHROME OR POWDER COAT	2,070
						
MG	0	30	08	TB	INCLUDES BRACKETS TO CONNECT BETWEEN TWO UPHOLSTERED UNITS	828

TO ORDER **1 SERIES/FRAME/STYLE** **2 FINISH** **3 OPTIONS** **4 FRAME FINISH CHOICES**

FOLLOW STEPS 1 - 4 TO CONSTRUCT A MODEL NUMBER.

SEE INTRODUCTORY PRODUCT SPECIFICATION PAGES FOR ADDITIONAL INFORMATION.

- **MG 43014TB**
30" X 14" FOUR LEG TABLE BENCH
- **MG 43024TB**
30" X 24" FOUR LEG TABLE BENCH
- **MG 43048TB**
30" X 48" FOUR LEG TABLE BENCH
- **MG 03008TB**
30" X 8" IN-LINE CONNECTING TABLE

SEE TABLET ARM PAGES FOR DETAILS.

- **STANDARD VENEER CHOICES**
PZ30 ALPI RIFT CUT OAK
MK33 TONED ALPI QUARTER CUT WENGE
- **SPECIAL ORDER**
ALL OTHER PAZ AND WELCOME FINISHES CAN BE SPECIAL ORDERED. PLEASE CONTACT STYLEX CUSTOMER SERVICE FOR PRICING AND LEAD-TIMES.
- **CUSTOM STAIN MATCH** +235
PER ORDER PER COLOR
10 UNIT MINIMUM

- **GA GANGING BRACKET** +31
ONE GANGING BRACKET SECURES TWO UNITS. FIELD-INSTALLABLE. UNITS WITH ARMS ON BOTH SIDES MAY NOT BE GANGED. UNITS WITH AN ARM ON ONE SIDE MAY BE GANGED ON THE SIDE WITHOUT AN ARM.

WHEN GANGING A GROUP OF CHAIRS, CALCULATE THE NUMBER OF CHAIRS TO ORDER WITH BRACKETS BY TOTALING THE NUMBER OF CHAIRS GANGED TOGETHER AND SUBTRACTING ONE.

- **STANDARD POWDER PAINT**
TB TEXTURED BLACK
GB GLOSSY BLACK
- **DOUBLE COAT POWDER PAINT***
MS METALLIC SILVER
* INCLUDES A PROTECTIVE CLEAR COAT
- **CH BRIGHT CHROME**

DESCRIPTION

LAMINATE

VENEERS

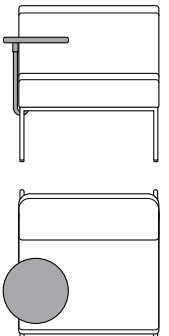
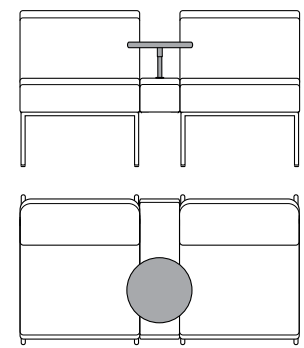
SERIES	FRAME	STYLE	FRAME	FRAME FINISH CHOICES	STANDARD LAMINATE	STANDARD VENEERS	
	MG	1	30	UTA	CHROME OR POWDER COAT	388	492
	MG	0	30	STA	CHROME OR POWDER COAT MUST BE ORDERED WITH IN-LINE CONNECTING TABLE	362	466

TO ORDER

1 SERIES/FRAME/STYLE

2 TABLET ARM OPTION

3 FRAME FINISH CHOICES

FOLLOW STEPS 1 - 3 TO
CONSTRUCT A MODEL NUMBER.

SEE INTRODUCTORY PRODUCT
SPECIFICATION PAGES FOR
ADDITIONAL INFORMATION.



MG 130UTA
UNIVERSAL TABLET ARM
13" ROUND TABLET

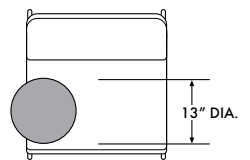
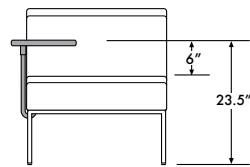

EDGE DETAIL .75" THICK

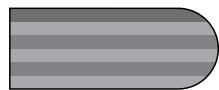

MG 030STA
SHARED TABLET ARM
13" ROUND TABLET

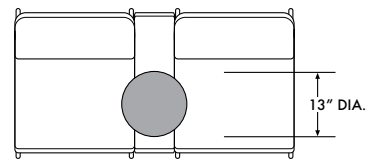
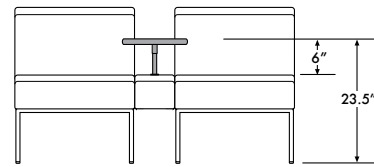

STANDARD LAMINATE CHOICES
BALTIC PLY EDGE

L10 FROSTY WHITE	WILSONART #
L11 BLACK	1573-60
L14 WHITE SAND	1595-60
	D403-60

STANDARD VENEER CHOICES
BALTIC PLY EDGE

PZ30 ALPI RIFT CUT OAK
MK33 TONED ALPI QUARTER CUT WENGE

SPECIAL ORDER
ALL OTHER PAZ AND WELCOME FINISHES
CAN BE SPECIAL ORDERED. PLEASE
CONTACT STYLEX CUSTOMER SERVICE
FOR PRICING AND LEAD-TIMES.



STANDARD POWDER PAINT

TB TEXTURED BLACK
GB GLOSSY BLACK

DOUBLE COAT POWDER PAINT*

MS METALLIC SILVER
* INCLUDES A PROTECTIVE
CLEAR COAT

CH BRIGHT CHROME