

PRICES EFFECTIVE
JANUARY 2011

S T I Y L E X



luna

price list

luna

PRODUCT INFORMATION

APPLICATIONS:

- STACKING
- MULTI-USE

FOUR LEG

FOUR LEG

FOUR LEG

GENERAL INFORMATION

DIMENSIONS / OVERVIEW

GUEST

COUNTER STOOL

BAR STOOL

GENERAL DIMENSIONS*

- A. AVERAGE SEAT HEIGHT
- B. SEAT DEPTH
- C. AVERAGE SEAT WIDTH
- D. BACK HEIGHT
- E. BACK WIDTH
- F. OVERALL WIDTH (FOOT PRINT)
- G. MAXIMUM OVERALL HEIGHT
- H. MAXIMUM OVERALL DEPTH

*WOOD SEAT/WOOD BACK AND UPHOLSTERED SEAT OPTION SHARE THE SAME DIMENSIONS

STACKING

UPHOLSTERY OPTION

UPHOLSTERED SEAT AND WOOD BACK

STACKING

- A. 17.5"
- B. 17.5"
- C. 18.5"
- D. 16.6"
- E. 18.4"
- F. 19.5"
- G. 32.7"
- H. 22.2"

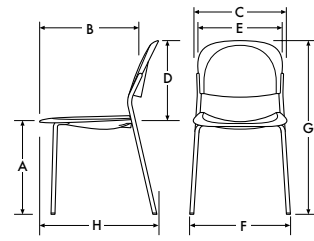

- 9 HIGH ON THE FLOOR
- 18 HIGH ON THE DOLLY

- A. 25.5"
- B. 17.5"
- C. 18.5"
- D. 16.6"
- E. 18.4"
- F. 20.5"
- G. 42"
- H. 24.2"

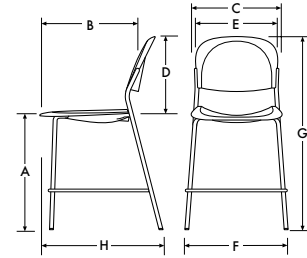

- 6 HIGH ON THE FLOOR

- A. 29.5"
- B. 17.5"
- C. 18.5"
- D. 16.6"
- E. 18.4"
- F. 20.5"
- G. 46"
- H. 24.2"

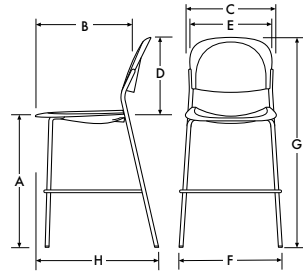

- 6 HIGH ON THE FLOOR

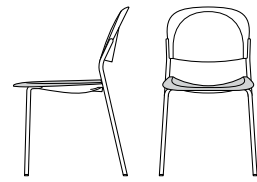

- 8 HIGH ON THE FLOOR
- 12 HIGH ON THE DOLLY

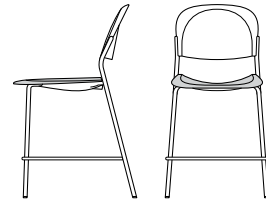

- 6 HIGH ON THE FLOOR

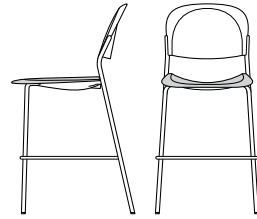

- 6 HIGH ON THE FLOOR

DESIGN

KOMPLIT DESIGN

CONSTRUCTION

SEATS AND BACKS INCORPORATE COMPOUND CURVE PLYWOOD FABRICATED FROM THINLY SLICED VENEERS. FRAMES ARE 13-GAUGE, HIGH-STRENGTH STEEL TUBE THAT MAY BE EITHER CHROME PLATED OR POWDER COATED IN ONE OF 12 COLORS. EXPOSED JOINTS ARE TIG WELDED. UPHOLSTERED SEATS USE HIGH-DENSITY, CFC-FREE POLYURETHANE FOAM.

GLIDES

GLIDES ARE BLACK PLASTIC.

STACKING

ALL CHAIRS STACK. SEE SPECIFIC MODEL FOR STACKING CAPACITY.

WOOD FINISHES

THE BEAUTY OF WOOD CONSISTS OF ITS BEING A PRODUCT OF NATURE. AS SUCH, EXPOSED WOOD SURFACES WILL NOT OFFER THE SAME CONSISTENCY AS MAN-MADE MATERIALS. SOME VARIATION IN COLOR, GRAIN, AND TEXTURE ARE TO BE EXPECTED, EVEN WITHIN THE SAME ORDER. ANOTHER CONSIDERATION IS THAT WOOD COMPONENTS WILL TEND TO DARKEN OVER TIME, EXAGGERATING SLIGHTLY NATURALLY OCCURRING DIFFERENCES. CHAIRS ORDERED AT DIFFERENT TIMES ARE LIKELY TO BE LESS SIMILAR THAN THOSE ORDERED TOGETHER. THEREFORE, STYLEX WILL NOT GUARANTEE A PRECISE MATCH OF COLOR, GRAIN, OR TEXTURE OF ITS WOOD COMPONENTS.

USE

DESIGNED FOR INDOOR USE ONLY.

TESTING

MANUFACTURED TO COMPLY WITH ANSI/BIFMA X5.1 GENERAL OFFICE CHAIR TESTS.

ENVIRONMENT





GREENGUARD CERTIFIED.

luna wood seat and wood back

MULTI-USE / STACKING
FOUR LEG ARMLESS
GUEST / COUNTER / BAR

DESCRIPTION

WOOD SEAT AND
WOOD BACK

SERIES	FRAME	STYLE	BACK	FRAME FINISH CHOICES		
 	ARMLESS LU	1	1	20	STANDARD POWDER DOUBLE COAT POWDER CHROME • STACKING: 9 HIGH ON THE FLOOR 18 HIGH ON DOLLY	440 465 492
 	ARMLESS BAR STOOL LU	7	1	20	STANDARD POWDER DOUBLE COAT POWDER CHROME • STACKING: 6 HIGH ON THE FLOOR COUNTER HEIGHT ALSO AVAILABLE	642 667 714

TO ORDER FOLLOW STEPS 1-5

1 SERIES/FRAME/STYLE 2 BACK TYPE 3 WOOD FINISH CHOICES 4 FINISH CHOICES ACCESSORY

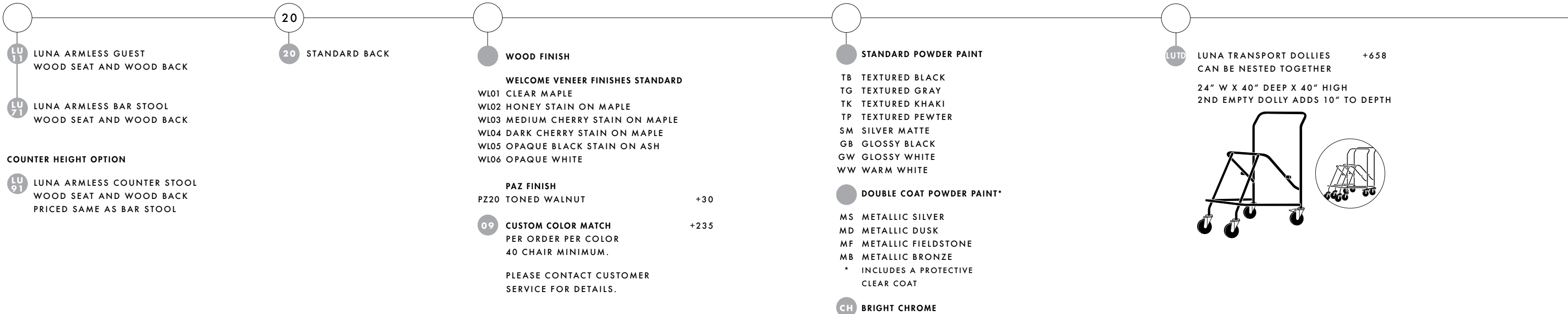

COUNTER HEIGHT OPTION

LU 91 LUNA ARMLESS COUNTER STOOL
WOOD SEAT AND WOOD BACK
PRICED SAME AS BAR STOOL

FINISH ADVISORY FOR STACKING STYLEX RECOMMENDS CHROME FRAMES FOR ANY STACKING APPLICATION REQUIRING DOLLIES. WE WILL NOT WARRANT POWDER COATED FRAMES USED ON DOLLIES AGAINST DAMAGE TO THE FINISH. IN ADDITION, APPROPRIATE CARE MUST BE EXERCISED WHEN STACKING POWDER COATED CHAIRS ON THE FLOOR.

luna upholstered seat and wood back

MULTI-USE / STACKING
FOUR LEG ARMLESS
GUEST / COUNTER / BAR

DESCRIPTION

C.O.M.





C.O.L.

FABRIC
UPHOLSTERY
GRADES

C.O.M.

C.O.L.

LEATHER
UPHOLSTERY
GRADES

SERIES	FRAME	STYLE	BACK	FRAME FINISH CHOICES	YDG.	SQ.FT.	A	B	C	D	E	F	G	H	I	J	W	X	Y	
 	ARMLESS LU	1	3	20	STANDARD POWDER	0.4	6	440	454	466	480	493	507	521	538	553	572	567	587	640
					DOUBLE COAT POWDER	0.4	6	465	478	491	505	517	532	545	562	578	597	592	611	665
					CHROME	0.4	6	492	506	518	532	544	559	573	589	605	624	619	639	692
• STACKING: 8 HIGH ON THE FLOOR 12 HIGH ON DOLLY																				
 	ARMLESS BAR STOOL LU	7	3	20	STANDARD POWDER	0.4	6	642	655	668	681	693	708	721	738	753	772	767	787	839
					DOUBLE COAT POWDER	0.4	6	667	681	693	707	719	733	747	764	779	798	793	812	865
					CHROME	0.4	6	714	728	740	753	766	780	794	810	826	845	839	859	912
• STACKING: 6 HIGH ON THE FLOOR COUNTER HEIGHT ALSO AVAILABLE																				

TO ORDER FOLLOW STEPS 1-6

1 SERIES/FRAME/STYLE	2 BACK TYPE	3 WOOD FINISH CHOICES	4 FINISH CHOICES	ACCESSORY	5 COVER
----------------------	-------------	-----------------------	------------------	-----------	---------

LU 13 LUNA ARMLESS GUEST UPHOLSTERED SEAT AND WOOD BACK

LU 73 LUNA ARMLESS BAR STOOL UPHOLSTERED SEAT AND WOOD BACK

COUNTER HEIGHT OPTION
LU 93 LUNA ARMLESS COUNTER STOOL UPHOLSTERED SEAT AND WOOD BACK PRICED SAME AS BAR STOOL

20 STANDARD BACK

WOOD FINISH

WELCOME VENEER FINISHES STANDARD

WL01 CLEAR MAPLE
WL02 HONEY STAIN ON MAPLE
WL03 MEDIUM CHERRY STAIN ON MAPLE
WL04 DARK CHERRY STAIN ON MAPLE
WL05 OPAQUE BLACK STAIN ON ASH
WL06 OPAQUE WHITE

PAZ FINISH

PZ20 TONED WALNUT +15

09 CUSTOM COLOR MATCH +235
PER ORDER PER COLOR
40 CHAIR MINIMUM.

PLEASE CONTACT CUSTOMER SERVICE FOR DETAILS.

STANDARD POWDER PAINT

TB TEXTURED BLACK
TG TEXTURED GRAY
TK TEXTURED KHAKI
TP TEXTURED PEWTER
SM SILVER MATTE
GB GLOSSY BLACK
GW GLOSSY WHITE
WW WARM WHITE

DOUBLE COAT POWDER PAINT*

MS METALLIC SILVER
MD METALLIC DUSK
MF METALLIC FIELDSTONE
MB METALLIC BRONZE
* INCLUDES A PROTECTIVE CLEAR COAT

CH BRIGHT CHROME

LUTD LUNA TRANSPORT DOLLIES +658
CAN BE NESTED TOGETHER
24" W X 40" DEEP X 40" HIGH
2ND EMPTY DOLLY ADDS 10" TO DEPTH

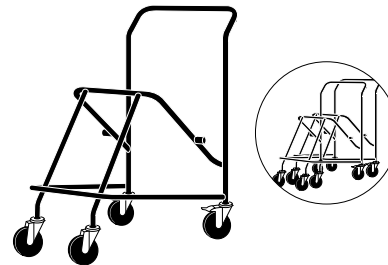

SEE SWATCH CARDS FOR STANDARD UPHOLSTERY OPTIONS.
SEE GENERAL INFORMATION SECTION FOR DETAILS ON COM AND IN-GRADED FABRIC PROGRAM.
SEE GENERAL INFORMATION SECTION FOR CAL 133 INFORMATION.

FINISH ADVISORY FOR STACKING STYLEX RECOMMENDS CHROME FRAMES FOR ANY STACKING APPLICATION REQUIRING DOLLIES. WE WILL NOT WARRANT POWDER COATED FRAMES USED ON DOLLIES AGAINST DAMAGE TO THE FINISH. IN ADDITION, APPROPRIATE CARE MUST BE EXERCISED WHEN STACKING POWDER COATED CHAIRS ON THE FLOOR.